



SmartVent

the expert's choice



POSITIVE PRESSURE SYSTEMS
HEAT & ENERGY RECOVERY SYSTEMS

PRODUCT GUIDE

Why SmartVent?

SmartVent is proudly owned by Simx, a business unit of the Volution Group. As a leading international designer and manufacturer of energy-efficient, indoor air quality solutions, Volution Group is committed to providing healthy air, sustainably.

An efficient home ventilation system may well be just a low-cost product that keeps moisture build-up at bay. An effective system, however, is an investment that delivers the quality of life we now expect as the minimum for in-home comfort. SmartVent offers a wide range of home ventilation solutions with systems designed to best suit the specific needs of any home today.

Over 40 years experience in the ventilation market

Simx, the distributors of SmartVent home ventilation systems, have been in operation for over 40 years in the ventilation industry.

SmartVent is the expert's choice

We are the choice of the professional trade market with most electricians recommending SmartVent.

Acoustic duct for quieter performance

Our unique acoustic insulated duct reduces air noise travelling down the duct and entering rooms the outlets are placed in.

State of the art controllers

SmartVent touchscreen controllers are designed in NZ, are fully automated and easy to use.

Complete flexibility

A SmartVent system provides the complete solution for any situation. We provide the best value upgrades on the market. In many cases, our customers purchase the standard system initially and add upgrades at a later stage, which seamlessly operate off their existing controller.

5-year warranty

Simx sources only the highest quality componentry and as such, all SmartVent systems are supported by a 5-year warranty.



SmartVent Home Ventilation Systems are recommended and installed by qualified electrical and HVAC contractors across the country.

Market feedback from these groups and consumers, along with ongoing investment in research and development has led to SmartVent having an incredibly flexible, future-proofed home ventilation systems in the New Zealand market.



Contents

Why SmartVent	2
Why Ventilate	4
What are we made of?	5
Positive Pressure Systems	6
Heat & Energy Recovery Systems	7
System Selection Guide	8
Traditional Ventilation vs Heat Recovery	9
System Comparison Table	10-11
System Comfort Add-ons	12
Systems:	
Lite+	13
Positive3	14
Positive Advance	15
Synergy3	16
Balance	17
Tempra	18
Fresh	19
PureAir Room 260X	20
Econiq	21
Specifications – Positive Pressure	22
Specifications – Heat & Energy Recovery	23

Why Ventilate?

Ventilating our homes creates and maintains the indoor air quality we need to ensure that a healthy environment exists for our everyday living.

Poorly ventilated homes can experience a range of issues from poor indoor air quality, such as increased mould growth, dampness, proliferation of dust mites, smelly VOCs (Volatile Organic Compounds) and overheating. These conditions can then lead to respiratory problems, allergies, and other health issues for occupants.

Many of us are not aware that the well-intentioned energy efficiencies we introduce to our homes often negatively affect the indoor air quality which can then compromise our health. In winter, the issue of poor indoor air quality is compounded further by the simple act of trying to keep our homes as warm as possible. Insulation solutions like double glazing and thicker walls make our homes easier to heat but can often limit ventilation and increase the need for good ventilation practices which are essential for creating a healthy living environment.

So how can you ventilate your home?

Why not just open a window? Opening windows may not be practical or safe, especially in areas with poor outdoor air quality, extreme temperatures, or high levels of noise pollution. Additionally, relying solely on open windows for ventilation may not provide consistent or sufficient airflow to effectively remove moisture and airborne pollutants or regulate indoor temperature.

What about a heat pump? While a heat pump indirectly helps with moisture by heating air, it does not bring in fresh air or provide the same level of air filtration and purification as a dedicated home ventilation system.

By taking an active approach to ventilation, you can ensure that you bring fresh, clean and filtered air into your home, while removing the damp, contaminated air. This way you can improve the health and wellbeing of both your family and home.

Being in a room with fresh air ventilation can reduce the transmission of airborne viruses by over **70%**



Over a year a family can produce over 6,000 litres of moisture in the air inside their home. Damp homes are much harder to heat than a dry one.



What are we made of?

With up to **69%** of your lifetime spent in your home, a comfortable and healthy living environment is the least you should expect.

Control is Easy

SmartVent solutions include a range of control options, backed up by quality components. System operation is, primarily, set-and-forget. Simply enter your preferred temperature and the system does the rest.

Your fully automated wall controller determines the amount of air required to ventilate your home while temperatures and moisture conditions change throughout the day and night. All systems can be manually operated if you want more control, and the flexibility of scheduling and seasonal add-ons gives you ultimate control over your home environment.

Filters

The filter is an important component of a ventilation system as it is responsible for cleaning all the air going into your home. On average, we breathe in 20-30kg of air every day, so it is essential that the atmospheric particles that can adversely affect our health are effectively, and efficiently, filtered out.

All centralised SmartVent systems feature high grade F7 filters that capture up to 90% of 0.4 micron particles such as fine pollens, dusts and allergens, making the air much cleaner to breathe. High quality HEPA filters are also available for asthma and allergy sufferers. Carbon filters are designed to filter out strong odours.

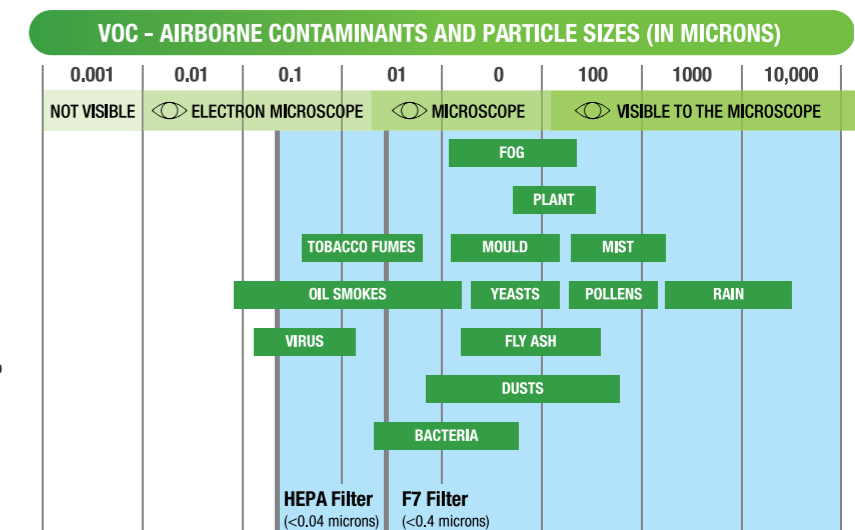

System Components and Add-ons

Dew Point Control

Most SmartVent systems use real humidity levels and temperatures to provide the right air at the right time.

Brushless EC fans

Most SmartVent systems use energy efficient brushless EC fans for lower running costs.

Insulated Ducting

All centralised SmartVent systems feature acoustic insulated ducting for quiet system performance. Most systems feature thermally insulated ducting.

Flexi Air Source

The optional Flexi Air Source add-on allows for effortless summer free-cooling and taking advantage of solar gain in winter.

Heat Transfer

Share the warmth from the lounge to the bedroom with this optional add-on.

Tempering Heater

Take the edge off the winter chill with this optional add-on.

POSITIVE PRESSURE SYSTEMS

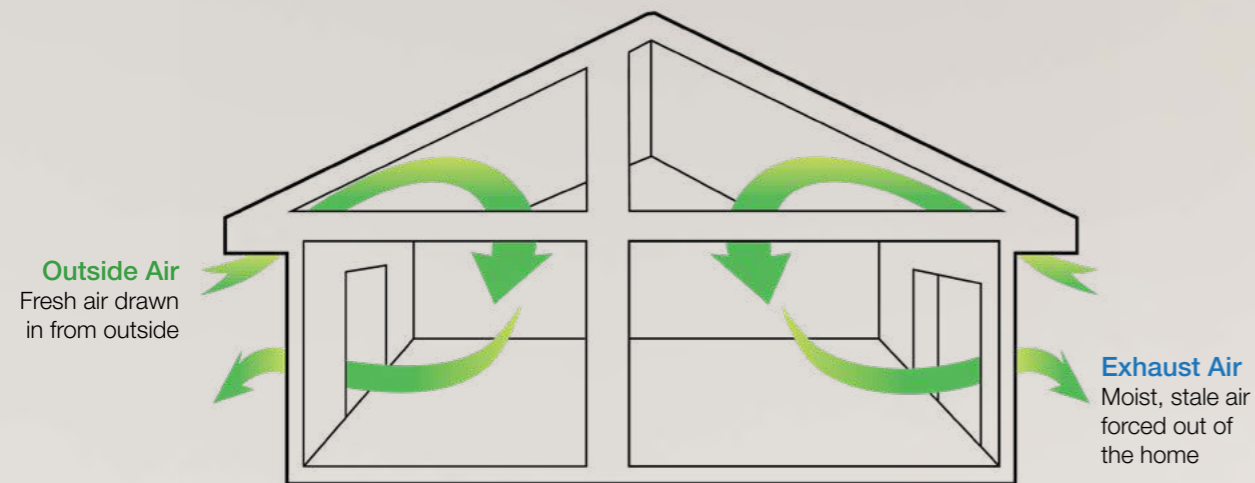

Positive Pressure Systems are ideal for managing moisture and humidity within your home. These systems draw in fresh air from the roof cavity and filter it before distributing the clean air around your home via a network of ceiling diffusers. The air movement forces the moist, stale air that causes condensation, mould and mildew out.

In winter especially, good air circulation and home heating are essential for maintaining indoor air quality. A home ventilation system from SmartVent reduces the excess damp, moisture-filled air and improves the overall air quality inside your home, making it much healthier for you and your family. A good investment for the well-being of your family and the overall health of your home.



HEAT & ENERGY RECOVERY SYSTEMS

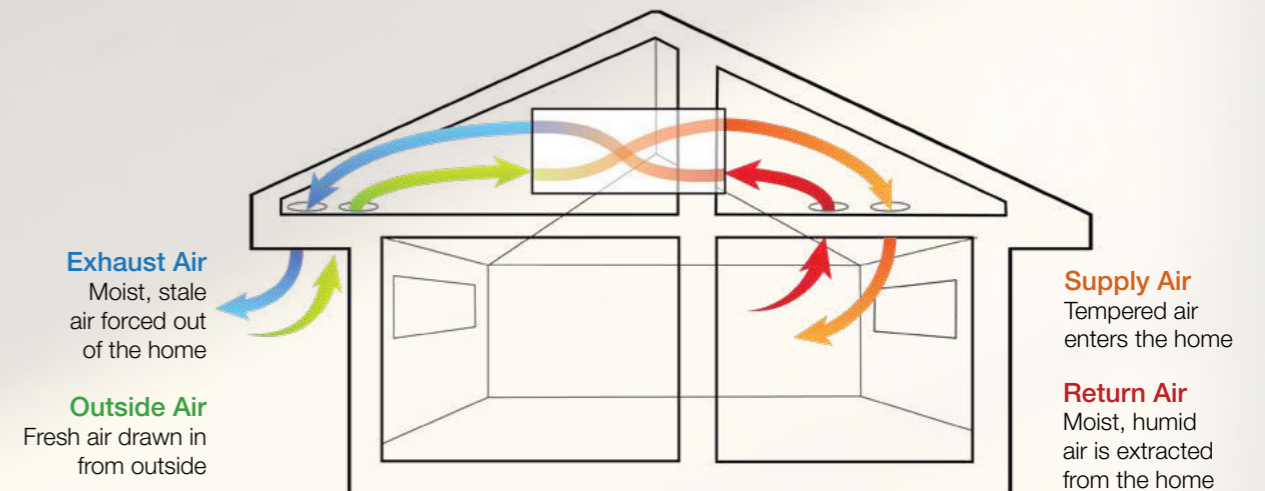

A Heat Recovery System is designed to bring fresh air into your home at a comfortable temperature. These systems recover heat or cooling energy from extracted room air as the heat recovery core transfers the heat from the outgoing air to the incoming air, warming or cooling your home respectively.

In winter, it is much more important that ventilation systems not only perform their basic function of extracting moist, stale air, but do so in a way that complements the costly efforts made to warm your home. System performance is best measured by the efficiency of the core. SmartVent has a wide range of Heat & Energy Recovery Systems, from highly efficient centralised systems designed for roof cavities, to decentralized through wall systems for either single rooms or an entire building.



System Selection Guide

All SmartVent Home Ventilation Systems will help provide a drier, healthier home, but there's more to it than that. Find the best solution for you:

Do you have a roof space?



Is comfort and noise a priority to you?



Do you want to save / recover energy?



Do you want to recover heat from your bathroom?



Do you want the best controls?



SmartVent balance

SmartVent synergy3

SmartVent positive advance

SmartVent positive3

Traditional Ventilation vs

Heat Recovery



Why Heat Recovery?

A heat recovery system can do more for you than just increasing your comfort while ventilating your home. When compared to a traditional ventilation system, it will make it more efficient to heat or cool your home, **lowering your power bill** throughout the year.

The following charts and graphs demonstrate how much of your heating bill you could save by installing a heat recovery system instead of a traditional ventilation system.

Cumulative Heating Cost Savings

North Island	2 Years	5 Years	10 Years
Auckland	\$ 1,268.28	\$ 3,170.69	\$ 6,341.38
Hamilton	\$ 1,348.54	\$ 3,371.34	\$ 6,742.68
Tauranga	\$ 1,348.54	\$ 3,371.34	\$ 6,742.68
Taupo	\$ 2,224.97	\$ 5,562.44	\$ 11,124.87
New Plymouth	\$ 1,750.61	\$ 4,376.53	\$ 8,753.06
Hawke's Bay	\$ 1,724.04	\$ 4,310.10	\$ 8,620.20
Palmerston North	\$ 1,952.94	\$ 4,882.35	\$ 9,764.69
Wellington	\$ 1,665.66	\$ 4,164.16	\$ 8,328.32

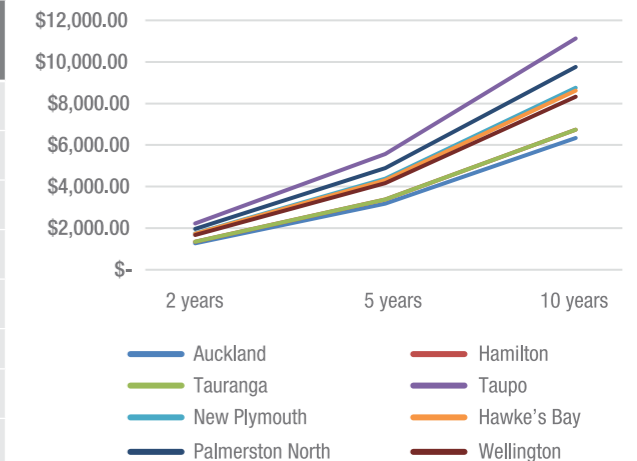

South Island	2 Years	5 Years	10 Years
Nelson	\$ 1,808.05	\$ 4,520.13	\$ 9,040.25
Christchurch	\$ 2,354.70	\$ 5,886.75	\$ 11,773.51
Greymouth	\$ 2,338.37	\$ 5,845.92	\$ 11,691.84
Queenstown	\$ 2,970.20	\$ 7,425.50	\$ 14,851.01
Dunedin	\$ 2,725.52	\$ 6,813.79	\$ 13,627.59
Invercargill	\$ 2,801.87	\$ 7,004.67	\$ 14,009.34

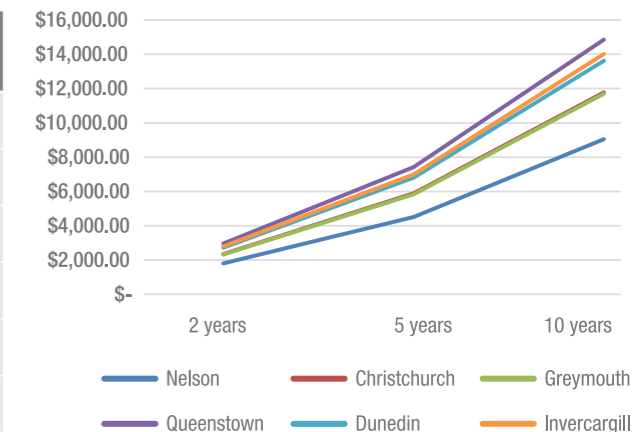

Mechanical ventilation with heat recovery units (MVHR) offer additional energy savings above and beyond that of a typical ventilation system. **Assumptions:** The savings shown here are purely based on potential heating cost savings when reheating air through a 90% efficient MVHR running continuously verses a direct air system to achieve 20°C+ year-round for an air volume based 0.35ACH in a 150m² house with a 2.4m ceiling height using electric heat at 30 cents/kWh.

Positive Pressure Systems

Heat & Energy Recovery Systems

SmartVent lite+



Investment Protection
Cost effective solution including an integral humidity guard against moisture, mould & mildew

SmartVent positive3



Control Condensation
Integral humidity guard against moisture, mould & mildew with multiple comfort add-on options

SmartVent positive advance



Control Your Climate
Comprehensive humidity control protection against moisture, mould & mildew with multiple comfort add-on options

SmartVent tempra



Ventilate Your Room
Single room heat recovery

SmartVent fresh



Coming soon

Flexible Ventilation for every space
Decentralised Heat Recovery Ventilation System

SmartVent synergy3



Control Indoor Climate
Reduce moisture, mould & mildew with multiple comfort add-on options

SmartVent balance



Combat Condensation
Reduce moisture, mould & mildew while maximizing energy efficiency

Systems	Lite+	Positive3	Positive Advance	Tempra	Fresh	Synergy3	Balance
Supply Rooms (Fresh air in)	1 - 12	1 - 12	2 - 12	Modular	Modular	3 - 6	3 - 6
Extract Rooms (Stale air out)				Simultaneous	Push-Pull	1 - 2	1 - 3
Moisture Control	Basic	Enhanced	Enhanced	Basic	Enhanced	Enhanced	Enhanced
Quicker pay back (Heat/energy recovery)				✓ (Up to 80%)	✓ (Up to 82%)	✓ (Up to 75%)	✓ (Up to 90%)
Cheaper to Run (EC Fan)		✓	✓		✓		✓
Heat retention (Insulated ducting)		✓	✓		✓	✓	✓
Quieter (Acoustic insulated ducting)		✓	✓		✓	✓	✓
Comfort Add-ons		Optional	Optional		Built-in	Optional	Built-in
Free-cooling (Flexi Air Source)		Optional	Optional		Extract Mode	Optional (Flexi Air Source)	✓
Heat Transfer		Optional	Optional			Optional	
Air Tempering		Optional (Tempering Heater)	Optional (Tempering Heater)	✓	✓	✓	✓
Controls & Sensors	3.5" Monochrome Touchscreen	3.5" Monochrome Touchscreen	6.8" Colour Touchscreen	3-speed	Optional	6.8" Colour Touchscreen	Wall Controller
App Control (SmartLife)		✓	✓		✓	✓	Not Required
Ease of Use	Basic	Basic	Enhanced	Basic	Advanced	Enhanced	Intermediate
Humidity & Temperature Sensing	✓ x2	✓ x3	✓ x4		✓ (+Expandable)	✓ x4	✓ (Built-in)
Rental Lock	✓	✓					
Scheduling	Daily	Daily	Weekly		Daily	Weekly	Daily

Comfort Add-Ons

SmartVent Positive Pressure and Heat & Energy Recovery Systems can be further enhanced with the addition of any of the following Comfort add-ons.



Flexi Air Source

During warmer months, outside air can be used as the primary air source for the system instead of roof cavity air. Keeping bug and pollen out overnight while bringing in a fresh filtered breeze when you need it most.

Typically installed under the eaves on the southern side of a home which ensures the coolest air possible is used. If the house design prevents a Flexi Air Source from being installed, alternative options such as through roof kits are available.

During cooler months, the Flexi Air Source can be used in the opposite way. This kit allows air to be drawn from the warmer roof cavity instead of outside, allowing you to automatically take advantage of any solar gain.



Heat Transfer

During cooler months, excess heat from your heated lounge can be transferred to your bedrooms. The recycle function is a bonus feature which allows inside air to be recirculated when outside temperatures are still too cold. It is important to remember that while heat transfer is active the system is not bringing fresh air in.

Heat Transfer is recommended when your home has a heat source that generates excess heat, such as a wood fire. It is important to note that a heat pump may not be suitable for heat transfer as they are typically sized for the room they occupy.



Tempering Heater

When it's cold outside and you want to take the chill off the incoming air, a 1kW or 2kW tempering heater allows you to make the most of the driest air available. Note that the tempering heater is not a home heating solution and is not a substitute for an effective heating system. The Tempering Heater will make the incoming air more comfortable, but not make your home dramatically warmer.

Systems with multiple fans need one heater per fan. For homes over 280m², systems require two fans, and some smaller homes may need two depending on layout. You may choose to only have one heater, but if your system has two fans some rooms will miss out on the benefits.

* Heat Transfer and Tempering Heater operations can be scheduled to maximise convenience.



Like a cold drink on a hot day, moisture will form when the temperature of the air drops while in contact with colder surfaces. This condensation is what happens when air reaches dew point.



SmartVent lite+



Overview

SmartVent Lite+ is a centralised positive pressure system that uses temperature and humidity sensing to ensure that you are protecting your home or rental property from moisture buildup. Two wireless temperature and humidity sensors measure moisture and temperature inside your home and outside to calculate the dew point.

As a temperature and humidity-based solution, the SmartVent Lite+ uses humidity control to increase or decrease airflow to control the moisture within a home or rental property. The rental lock feature enables a property owner to lock the controller to prevent tenants from switching the system OFF while still allowing system temperatures, fan speeds and ventilation scheduler adjustments to suit the lifestyles/needs of the occupants. The Lite+ also features low temperature protection, a short run of acoustically insulated ducting, and a user-friendly control system.

Investment Protection

Cost effective solution including an integral humidity guard against moisture, mould and mildew

SmartVent Lite+ Range

Basic home ventilation system best suited for rental properties.

What is the size of your home (m ²)?	Number of Rooms	Fans	Model
Up to 100m ²	1	1	SV01L+
	2		SV02L+
	3		SV02L+ with 1 Extension Kit
Up to 280m ²	4	1	SV04L+
	5		SV04L+ with 1 Extension Kit
	6		SV04L+ with 2 Extension Kits
Up to 560m ²	6	2	SV06L+
	7		SV06L+ with 1 Extension Kit
	8		SV06L+ with 2 Extension Kits
	9		SV06L+ with 3 Extension Kits
	10		SV06L+ with 4 Extension Kits
	11		SV06L+ with 5 Extension Kits
12	SV06L+ with 6 Extension Kits		

Add-Ons

Lite+ is not compatible with our range of comfort add-ons. For added comfort and flexibility check out our other options

Features	
Humidity Sensing	x2
Temperature Sensing	x2
Low Temperature Protection	
Auto or Manual Operation	AUTO MAN
Rental Property Lock	
Boost Control	
Filter Change Alert	
Screen Brightness Control	
Scheduler	DAILY

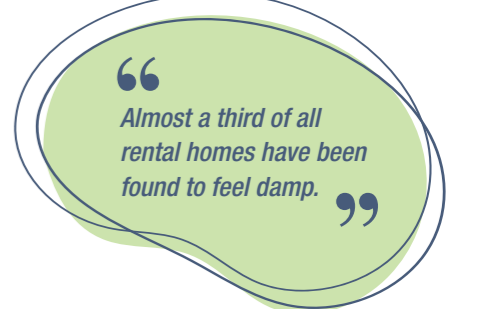



Condensation Control

Integral humidity guard against moisture, mould and mildew with multiple comfort add-on options

Overview

SmartVent Positive3 is a centralised positive pressure system that monitors temperature and humidity conditions in your home, roof cavity, and at the outside source, to ensure that your home is kept dry, and your air is fresh. Two wireless temperature and humidity sensors mean sensors can be placed in the optimum locations and not limited by cabling.

As a temperature and humidity-based solution, the SmartVent Positive3 uses dew point control to increase or decrease airflow to control the moisture within a home. The SmartVent Positive3 has several key features, such as its energy efficient brushless EC fans, acoustic and thermally insulated ducting, low temperature protection, and a user-friendly control system and App control (SmartLife). The flexible upgrade options allow users to customise the system to suit their individual needs.

SmartVent Positive3 Range

Enhanced home ventilation system suitable for most types of homes.

What is the size of your home (m ²)?	Number of Rooms	Fans	Model
Up to 100m ²	1	1	SV01P3
	2		SV02P3
	3		SV02P3 with 1 Extension Kit
Up to 280m ²	4	1	SV04P3
	5		SV04P3 with 1 Extension Kit
	6		SV04P3 with 2 Extension Kits
Up to 560m ²	6	2	SV06P3
	7		SV06P3 with 1 Extension Kit
	8		SV06P3 with 2 Extension Kits
	9		SV06P3 with 3 Extension Kits
	10		SV06P3 with 4 Extension Kits
	11		SV06P3 with 5 Extension Kits
12	SV06P3 with 6 Extension Kits		

Add-Ons

Flexi Air Source	Heat Transfer	Tempering Heater Small (1kW)*	Tempering Heater Large (2kW)*	Through Wall Grille

*Larger systems for homes above 280m² with two fans will require two tempering heaters (one for each fan)



Control Your Climate

Comprehensive humidity control protection against moisture, mould and mildew with multiple comfort add-on options

Overview

SmartVent Positive Advance is a centralised positive pressure system that uses advanced automation for enhanced moisture control. Four wireless temperature and humidity sensors measure moisture and temperature throughout the home, in the roof cavity and outside to calculate the dew point.

This comprehensive solution can then determine how much fresh air to introduce to prevent the temperature from reaching dew-point and causing condensation on windows. The market-leading Positive Advance comes with a range of features such as flexible upgrade options, weekly scheduling, dew point control, energy efficient brushless EC fans, and acoustic and thermally insulated ducting, as well as an intuitive wall controller and App control (SmartLife). Just set the preferred temperature and the system does the rest.

SmartVent Positive Advance Range

Comprehensive home ventilation system suitable for most types of homes.

What is the size of your home (m ²)?	Number of Rooms	Fans	Model
Up to 100m ²	2	1	SV02AD
	3		SV02AD with 1 Extension Kit
Up to 280m ²	4	1	SV04AD
	5		SV04AD with 1 Extension Kit
	6		SV04AD with 2 Extension Kits
Up to 560m ²	6	2	SV06AD
	7		SV06AD with 1 Extension Kit
	8		SV06AD with 2 Extension Kits
	9		SV06AD with 3 Extension Kits
	10		SV06AD with 4 Extension Kits
	11		SV06AD with 5 Extension Kits
12	SV06AD with 6 Extension Kits		

Add-Ons

Flexi Air Source	Heat Transfer	Tempering Heater Small (1kW)*	Tempering Heater Large (2kW)*	Through Wall Grille

*Larger systems for homes above 280m² with two fans will require two tempering heaters (one for each fan)



Features	
App Control	
WiFi Connect	
Dew Point Control	
Humidity Sensing	
Temperature Sensing	
Low Temperature Protection	
Auto or Manual Operation	
Boost Control	
Filter Change Alert	
Screen Brightness Control	
Scheduler	

SmartVent synergy3



Overview

SmartVent Synergy3 is a centralised energy recovery system that uses advanced automation for enhanced moisture control and improved heat retention. Four wireless temperature and humidity sensors measure moisture content throughout the home, in the roof cavity and outside to calculate dew point. While ideal for any home more air-tight construction enhances the energy recovery benefits.

This comprehensive solution can then determine how much fresh air to introduce to prevent the temperature from reaching dew point and causing condensation on windows. The SmartVent Synergy3's heat recovery core has an efficiency of up to **75%**, so you can ventilate your home in winter without having to spend a fortune re-heating it. Synergy3 also features flexible upgrade options, weekly scheduling, dew point control, and acoustic and thermally insulated ducting, as well as an intuitive wall controller and App control (SmartLife).

SmartVent Synergy3 Range

Home ventilation system best suited to homes built to modern standards.

What is the size of your home (m ²)?	Description	Model
Up to 150m ²	3 supply outlets/1 extract (expandable to 4 outlets /2 extracts*)	SYN1015AD
Up to 250m ²	3 supply outlets/1 extract (expandable to 5 outlets /2 extracts*)	SYN2025AD
Up to 350m ²	3 supply outlets/1 extract (expandable to 6 outlets /2 extracts*)	SYN3035AD

#Contact SmartVent for design advice if more outlets or extracts are required

Add-Ons

Flexi Air Source	Heat Transfer	Tempering Heater Small (1kW)*
Tempering Heater Large (2kW)*	Through Wall Grille	

Control Indoor Climate

Reduce moisture, mould and mildew with multiple comfort add-on options

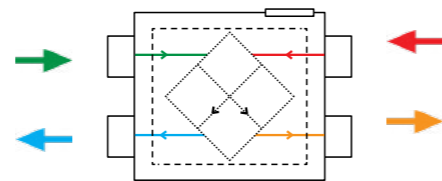

Features	
App Control	
WiFi Connect	
Dew Point Control	
Humidity Sensing	
Temperature Sensing	
Low Temperature Protection	
Auto or Manual Operation	
Core Efficiency (°C)	Up to 75%
Boost Control	
Filter Change Alert	
Screen Brightness Control	
Scheduler	



SmartVent balance



Overview

SmartVent Balance is an energy efficient centralised heat recovery ventilation system that uses advanced automation and an advanced heat recovery core to ventilate a home with minimal heat losses. The unit is a complete home solution with built-in sensors which record humidity and temperature as air flows through the unit. While ideal for any home more air-tight construction enhances the energy recovery benefits.

Using an integral counterflow heat exchanger, up to **90%** of heat energy can be recovered from your home, maximising energy efficiency. Running costs are further minimised with energy efficient brushless EC motors. The Balance's polymer heat recovery core enables heat transfer and extraction from wet zones like bathrooms, which is useful in continuous applications. A built-in core bypass allows for effortless summer operation. Acoustic and thermal ducting is also present, for quiet and efficient running. The SmartVent Balance is designed for completely autonomous operation, but the unit's digital controller is still available if manual operation is desired.

Combat Condensation

Reduce moisture, mould and mildew while maximizing energy efficiency

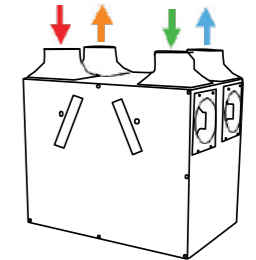

SmartVent Balance Range

Home ventilation system best suited to homes built to modern standards.

What is the size of your home (m ²)?	Description	Model
Up to 150m ²	3 supply outlets/1 extract (expandable to 4 outlets /2 extracts*)	BAL225
Up to 250m ²	5 supply outlets/2 extract (expandable to 6 outlets /3 extracts*)	BAL405

#Contact SmartVent for design advice if more outlets or extracts are required

Add-Ons

Due to its advanced systems, built-in core bypass and highly efficient heat recovery core, Balance does not require any add-ons.

Features	
Humidity Sensing	
Temperature Sensing	
Auto or Manual Operation	
Core Efficiency (°C)	Up to 90%
Core Bypass	
Boost Control	
Filter Change Alert	



SmartVent tempra

Overview

SmartVent Tempra is a single room through wall heat recovery unit suitable for residential retrofit and new builds, elderly care facilities, student accommodation, military barracks, apartments and locations with no roof cavity access.

SmartVent Tempra meets the performance requirements for continuous ventilation under the NZ Building Regulations. With a 100mm diameter heat recovery outlet, these easy-to-use units have low energy consumption and low noise levels.

Based on a 2.4m stud and 0.35 ACH (as per NZS4303.1990), SmartVent Tempra can be set to run continuously at 6 l/s (for rooms up to 25m²) or 9 l/s (for rooms up to 37m²), boosting up to 13 l/s, recovering heat energy from the extracted air and returning it to the dwelling.

The unique, compact heat exchanger has a core efficiency of up to **80%**, saving energy and reducing your carbon footprint while providing quality ventilation in situations where a traditional heat recovery ventilation system is not practical.

SmartVent Tempra Range

Length	Rooms	Description
450mm	1	Standard Tube
590mm	1	Long Tube

Performance

Specification	Trickle – Low	Trickle – High	Boost
Free Air Performance	6 l/s	9 l/s	15 l/s
Power	3.2W	5.7W	26.6W
Sound*	27.3 dB(A)	35.9 dB(A)	48.8 dB(A)

* Octave band frequency range of 250Hz to 4KHz at 3m.
Unit mounted on a reflective surface.



Ventilate Your Room

Single room heat recovery

- Constant trickle ventilation (24 hours, 7 days) with airflow boost option
- Separated airflows so that extracted moisture is not re-introduced
- Consistently higher heat recovery than units that use “extract-supply cycling” methods
- Low energy consumption
- Low noise
- Security - reduces risk of theft as windows are not required to be left open.
- Can be switched to ‘extract only’ if desired

Heat Exchanger

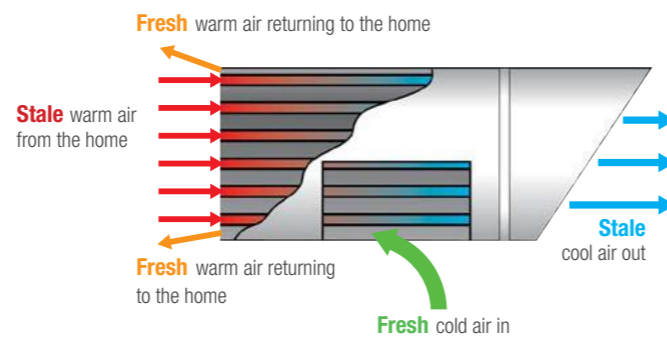
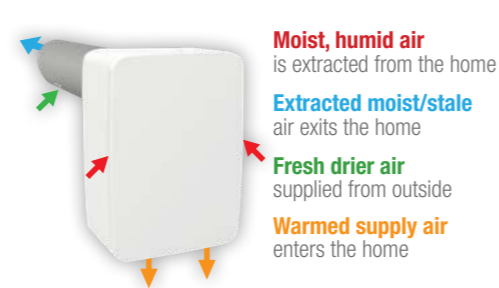

SmartVent fresh

Overview

The Fresh is a wall-mounted ventilation system designed to both supply and remove air from a space, while maintaining a comfortable temperature indoors through heat recovery. It's installed through the exterior wall of your home so it's perfect for downstairs spaces, homes with no roof access or roof space, apartments, basements and more.

The SmartVent Fresh is a decentralised heat recovery system that works by absorbing energy in its ceramic core before reversing and returning that energy to the incoming air. It can scale to provide ventilation from individual rooms to entire properties. The units work stand-alone or communicate wired or wirelessly with up to 16 devices/sensors across 4 Ventilation Zones. Plus the system supports simple manual modes and advanced configuration via Bluetooth.

SmartVent Fresh Range

Wall Depth	Rooms	Description
≥140	1-4	SmartVent Fresh - dMVHR Decentralised Mechanical Heat Recovery with App control

Optional Automation

Automate your system via add-ons like humidity, temperature, and CO₂ sensors, or easily operate manually.



Performance

Specification	Trickle (25%)	Medium (40%)	High (70%)	Boost (100%)
Efficiency	82%	72%	68%	60%
Extract/Heat Recovery (Pair)*	5.5 l/s (20m ³ /hr)	7.2 l/s (26m ³ /hr)	11.1 l/s (40m ³ /hr)	16.1 l/s (58m ³ /hr)
Power (Pair+Controller)	2.6W	3.5W	2.65W	5.05W
Heat Recovery (Single)*	2.8 l/s (10m ³ /hr)	3.6 l/s (10m ³ /hr)	5.5 l/s (20m ³ /hr)	8 l/s (28m ³ /hr)
Power (Single)	1.3W	1.75W	2.65W	5.05W
Sound	12dB(A)	24dB(A)	30dB(A)	37dB(A)

COMING SOON



FLEXIBLE VENTILATION for every space

Features	
App Control	
WiFi Connect	
Humidity Sensing	
Temperature Sensing	
Auto or Manual Operation	
Core Efficiency (°C)	Up to 82%
Trickle Ventilation	
Boost Control	
Filter Change Alert	
Scheduler	



PureAir Room 260X



PURIFY YOUR INDOOR AIR FOR A HEALTHIER HOME ENVIRONMENT

Overview

The Vent-Axia PureAir Room provides a safe space for people suffering from allergies or who want to be sure they are not breathing in harmful pollutants and wish to improve their indoor air quality. The filters of an air purifier will remove airborne contamination and allergens such as dust, pollen, animal dander, dust mites, tobacco smoke, traffic fumes and more. Removing these can make a positive impact to the indoor air you breathe and therefore help to improve your health and wellbeing.



Mould

Mycotoxins released by mould spores can cause headaches, eczema & lung conditions such as asthma



Dust

Household dust can be an irritant to our skin and lungs. It is also perfect food for dust mites which produce allergens



Viruses

Bacteria and viruses spread easily around the home in the air causing cold and flu like symptoms



Odour

Odour can be unpleasant but odour caused by pollutants like aerosols and air fresheners can be detrimental to your health

PureAir Room 260X Range

Description	
PureAir Room 260X Air Purifier with App Control (Smart Life)	
PureAir Room 260X Replacement Filter	

Technical

Supply	220–240V AC, 50Hz	Rated Power	60W
Air Flow Rate	260m³/h	Room size	30m²
Timer	1-8 hours	Noise Range	27-45 dB(A)
Dimensions (W*D*H)	350 x 210 x 550mm	Weight	5.8 kg



Advanced 6 Stage Filtration System

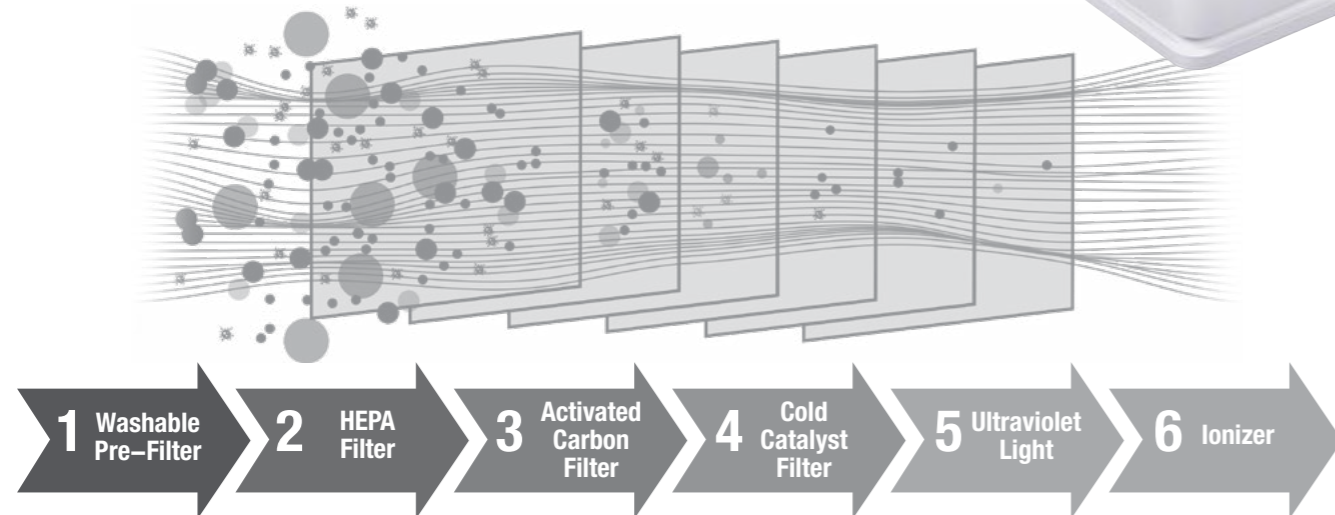

Ideal Room Types

Living Room

Dining Room

Bedroom

Nursery

Office

2
yr
WARRANTY



COMING SOON

Econiq

for New Build Residential



Overview

The Vent-Axia Econiq is a new, cutting-edge heat recovery ventilation system from Vent-Axia, specifically designed to offer the highest level of comfort and functionality all-year round. The unit is a complete home solution with built-in sensors which record humidity and temperature as air flows through the unit. Ideal for properties built after 2002.

High Efficiency Core

Recovers up to 93% of heat energy.

Easy to Use Controls

On-board digital display and app connectivity provide an intuitive user interface. Dirty air out, clean air in: G4 filters come as standard.

Energy Efficient

Powerful, quiet and energy-efficient brushless EC3 motors supply filtered air with high performance.

Ultra-Quiet Performance

With a noise level as low as 15.5 dB(A), the Econiq is one of the quietest ventilation systems on the market.

Advanced Automation

Using an integral humidity and temperature sensor, the unit is able to automatically adjust ventilation rates to suit conditions.

Summer Bypass

A built-in core bypass allows for effortless summer operation.

Polymer Core

Enables extraction from wet rooms for all-in-one ventilation solutions.



Specifications	SV01L+	SV01P3	SV02L+	SV02P3	SV02AD	SV04L+	SV04P3	SV04AD	SV06L+	SV06P3	SV06AD
House Size	Up to 100m ²		Up to 100m ²		Up to 280m ²		Up to 280m ²		Up to 560m ²		Up to 560m ²
Max. Fans	2	4	2	4	2	4	2	4	2	4	4
Fan Type	AC	EC	AC	EC	AC	EC	AC	EC	AC	EC	EC
Spigot Size	150mm		150mm		200mm		200mm		200mm		200mm
Fan Speeds	3	Infinately Variable	3	Infinately Variable	3	Infinately Variable	3	Infinately Variable	3	Infinately Variable	Infinately Variable
Max. Air Flow per Fan @ 0 Pa	152 l/s, 548m ³ /hr	175 l/s, 630m ³ /hr	152 l/s, 548m ³ /hr	175 l/s, 630m ³ /hr	282 l/s, 1014m ³ /hr	284 l/s, 1023m ³ /hr	282 l/s, 1014m ³ /hr	284 l/s, 1023m ³ /hr	282 l/s, 1014m ³ /hr	284 l/s, 1023m ³ /hr	284 l/s, 1023m ³ /hr
Max. Air Flow per Fan @ 150 Pa	98 l/s, 353m ³ /hr	132 l/s, 480m ³ /hr	98 l/s, 353m ³ /hr	132 l/s, 475m ³ /hr	211 l/s, 760m ³ /hr	206 l/s, 742m ³ /hr	211 l/s, 760m ³ /hr	206 l/s, 742m ³ /hr	211 l/s, 760m ³ /hr	206 l/s, 742m ³ /hr	206 l/s, 742m ³ /hr
Max. Static Pressure per Fan	336 Pa	568 Pa	336 Pa	568 Pa	441 Pa	461 Pa	441 Pa	461 Pa	441 Pa	461 Pa	461 Pa
Power Supply	220–240V AC 50 Hz		220–240V AC 50 Hz		220–240V AC 50 Hz		220–240V AC 50 Hz		220–240V AC 50 Hz		220–240V AC 50 Hz
Input Power per Fan	57W	67W	57W	67W	105W	85W	105W	85W	105W	85W	85W
Current (A) per Fan	0.26A	0.29A	0.26A	0.29A	0.47A	0.7A	0.47A	0.7A	0.47A	0.7A	0.7A
Operating Temp	–25°C to 50°C		–25°C to 50°C		–25°C to 50°C		–25°C to 50°C		–25°C to 50°C		–25°C to 50°C
Sound Level	47 dB(A)		47 dB(A)		53 dB(A)		53 dB(A)		53 dB(A)		53 dB(A)

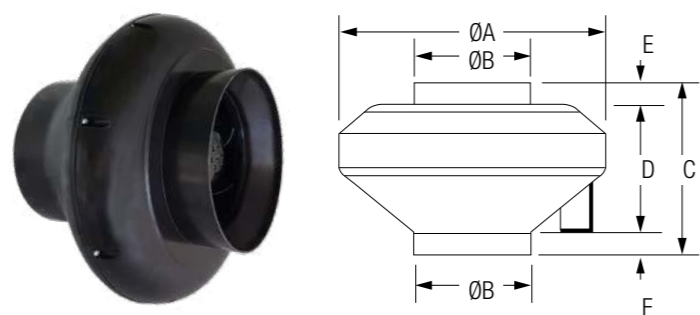

Fan Dimensions (mm)	A	B	C	D	E	F
Spigot Size – 150mm	340	150	280	170	50	60
Spigot Size – 200mm	340	200	280	170	50	60

Specifications	SYN1015AD	SYN2025AD	SYN3035AD	BAL225	BAL405
Fan Type	AC Centrifugal			EC Centrifugal	EC Centrifugal
Max. Fan Cores	2			–	
Spigot Size	150mm			125mm	150mm
Fan Speeds	3			10	
Max. Air Flow per Fan @ 0 Pa	77 l/s, 277m ³ /hr	97 l/s, 350m ³ /hr	130 l/s, 468m ³ /hr	76 l/s, 275m ³ /hr	136 l/s, 490m ³ /hr
Max. Air Flow per Fan @ 150 Pa	38 l/s, 137m ³ /hr	60 l/s, 216m ³ /hr	90 l/s, 324m ³ /hr	62 l/s, 223m ³ /hr	110 l/s, 395m ³ /hr
Max. Static Pressure per Fan	238 Pa	285 Pa	354 Pa	380 Pa	600 Pa
Power Supply	230–240V AC 50 Hz			220–240V AC 50 Hz	
Total Input Power	120W	178W	280W	128W	173W
Current (A)	0.46A	0.7A	1.1A	0.58A	0.79A
Operating Temp	–10°C to 40°C			–20°C to 45°C	
Sound Level	31.5 dB(A)	34 dB(A)	37 dB(A)	39 dB(A)	

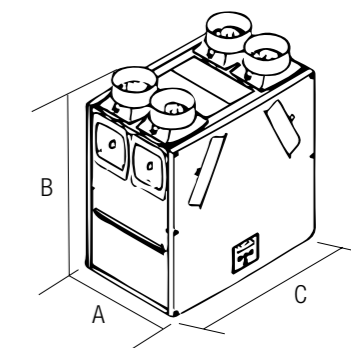
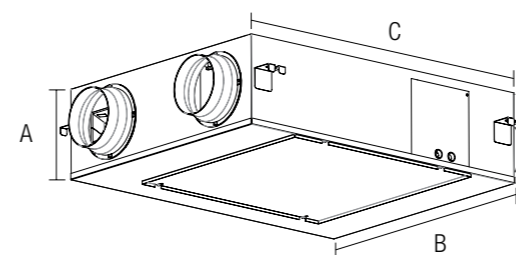

Energy Recovery Core Dimensions (mm)	A	B	C
SYN1015AD	230	690	860
SYN2025AD	230	710	930
SYN3035AD	240	820	1070

Heat Recovery Core Dimensions (mm)	A	B	C
BAL225	285	650	550
BAL405	524	745	776

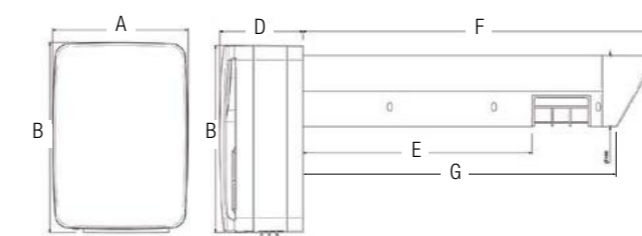

Tempra Dimensions (mm)	A	B	C	D	E	F	G
Standard Tube	190	266	262	117	321	496	450
Long Tube	190	266	262	117	461	636	590

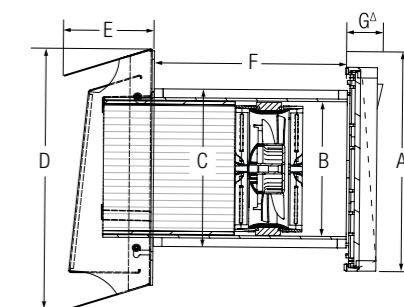

Fresh Dimensions (mm)	A	B	C	D	E	F	G
Standard	270	Ø160	Ø180	276	80	≥140	44

ΔFlush mount face available



SmartVent

the expert's choice

HOME VENTILATION SYSTEMS

Ask how we can do it for you

General enquiries ph: 0800 140 150

www.smartvent.co.nz | enquiry@smartvent.co.nz



The team at SmartVent is committed to our sustainability goals including reusing all packaging bearing this mark  please ask your installer for more information on this exciting initiative.

Specifications are subject to change without notice

By Simx | PUB0181 2407